

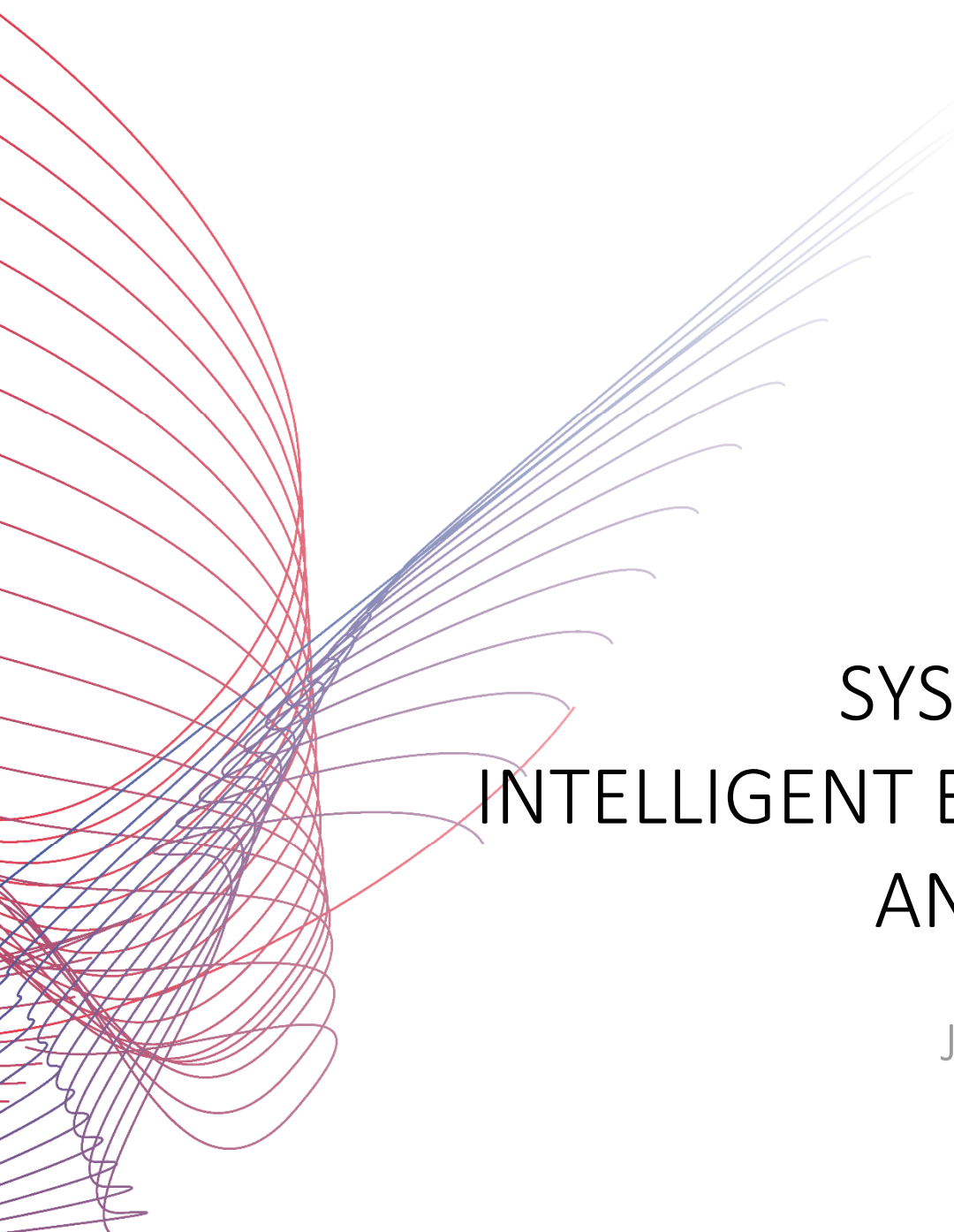

TECH pedia

An abstract graphic consisting of numerous overlapping, curved lines in shades of red and blue. The lines originate from the left side of the page and fan out towards the right, creating a sense of motion and complexity. The lines are thin and delicate, creating a mesh-like effect.

SYSTEMS FOR INTELLIGENT BUILDINGS AND HOMES

JAROSLAV ŠÍPAL

Title: Systems for Intelligent Buildings and Homes
Author: Jaroslav Šípál
Published by: Czech Technical University of Prague
Faculty of electrical engineering
Contact address: Technická 2, Prague 6, Czech Republic
Phone Number: +420 224352084
Print: (only electronic form)
Number of pages: 39
Edition: 1st Edition, 2017
ISBN 978-80-01-06222-7

TechPedia
European Virtual Learning Platform for
Electrical and Information Engineering
<http://www.techpedia.eu>



This project has been funded with support from the European Commission.
This publication reflects the views only of the author, and the Commission cannot be held responsible for any use which may be made of the information contained therein.

EXPLANATORY NOTES

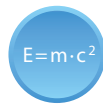

Definition



Interesting



Note



Example



Summary



Advantage



Disadvantage

ANNOTATION

This module provides introduction to building automation. It describes integrated technologies as building security systems, transportation systems, energy management systems and optimization of working conditions. Description of building sensors, actuators used, control systems, buses and protocols is also provided.

OBJECTIVES

Access control and security control systems (securing of the doors, semi-intelligent readers, closed-circuit television, fire alarm system, ...)

Transportation systems (possibility of people and goods movement in the building)

Facility management based on the control system

Building technologies managed by control system

Possibilities of the sensors and actuators in building technologies

Building management control systems by using buses and standard protocols

LITERATURE

- [1] ŠÍPAL, Jaroslav. Moderní předávací stanice. [s.l.] : [s.n.], 2007. 102 s. ISBN 978-80-7044-924-0
- [2] http://en.wikipedia.org/wiki/Access_control
- [3] http://en.wikipedia.org/wiki/Keychain#Access_control_key_fobs
[<http://en.wikipedia.org/wiki/Keychain>]
- [4] http://en.wikipedia.org/wiki/Fire_alarm_system
- [5] <http://en.wikipedia.org/wiki/Elevator>
- [6] <http://oze.tzb-info.cz/solarni-kolektory/typy-solarnich-kolektoru>
- [7] http://en.wikipedia.org/wiki/Closed-circuit_television
- [8] <http://en.wikipedia.org/wiki/HVAC>
- [9] http://en.wikipedia.org/wiki/Building_automation

- [10] <http://cs.wikipedia.org/wiki/Aktu%C3%A1tor> [<http://cs.wikipedia.org/wiki/Aktuátor>]
- [11] <http://cs.wikipedia.org/wiki/Senzor>
- [12] http://en.wikipedia.org/wiki/Safety_instrumented_system
- [13] http://en.wikipedia.org/wiki/Safety_integrity_level
- [14] http://cs.wikipedia.org/wiki/Neuronov%C3%A1_s%C3%AD%C5%A5
[http://cs.wikipedia.org/wiki/Neuronová_sít]
- [15] http://cs.wikipedia.org/wiki/Fuzzy_logika

Index

- 1 Introduction to Building Automation..... 7**
- 2 Building Safety Technologies 8**
 - 2.1 Access to the Building..... 9
 - 2.2 Closed-Circuit Television..... 12
 - 2.3 Fire Protection Systems..... 14
- 3 Transport Systems 15**
- 4 Building Energy Management 17**
- 5 Optimization of Working Conditions..... 18**
 - 5.1 Lighting 19
 - 5.2 Ventilation 20
 - 5.3 Heating 21
 - 5.4 Air Conditioning..... 22
- 6 Sensors in Buildings 23**
- 7 Actuators in Buildings 27**
- 8 Control Systems..... 28**
- 9 Buses and Protocols..... 30**
 - 9.1 Buses 31
 - 9.2 RS-232..... 32
 - 9.3 RS-422..... 33
 - 9.4 RS-485..... 34
 - 9.5 Modbus..... 36
 - 9.6 Other Protocols Used in Buildings..... 37
- 10 Supervisory Control Systems 38**

1 Introduction to Building Automation

One of the areas where automation is used more and more often nowadays is the building automation. Thanks to the application of the technology, we can now call some buildings “intelligent” or “smart” ones.

With respect to the purpose of the intelligent building use, we can divide them to:

- Residential buildings,
- Buildings providing services (schools, hospitals, offices, shops),
- Production buildings,
- Storage buildings.

The priority is to build a safe building, which is environment-friendly and has low energy consumption. This leads to higher deployment of automation technologies and so-called “Intelligent Buildings”.

Facility management of the buildings based on automation technologies is focused on the following areas:

- Ensuring the safety of inhabitants and their properties,
- Transport of people and goods inside the building,
- Reducing energy costs,
- Optimization of working conditions.

The importance of each area depends on the building’s purpose.

In general, it is possible to describe automation procedure by the following steps, which are also applied in building automation:

1. Information needed for the control process is acquired from the sensors.
2. Information is transmitted to the control center, where it is analysed and commands for actuators are issued.
3. Actuators take action to perform the requested reactions.

From the management point of view, there are two basic ways of control:

- Logical control, which is described in the theory of automation by functions of Boolean algebra;
- Regulation, where a regulator ensures the maintenance of selected physical quantities within the prescribed limits.

2 Building Safety Technologies

Building safety technology focuses primarily on ensuring the safety of persons and property inside the building. Securing of the object is dependent on the purpose of the building and, in general, it can be divided into three main categories:

- Access control of persons and vehicles,
- Closed-circuit television (CCTV),
- Fire Protection Systems.

2.1 Access to the Building

The first step towards building security is Access Control System. The access can be granted globally for the entire building or selectively for defined parts of the building.

In the role of the actuators, doors and turnstiles are used. Historical development began with mechanical security locks. Due to the fact that a mechanical key can be easily counterfeited or even stolen, mechanical locks are not recognised as sufficient to meet modern access control requirements.

The keys are being replaced with electronic chips in the form of pendants, usually containing a passive RFID tag. The sensor at the door identifies the key holder through wireless communication and transmits this information to a central server, which stores the database of chips. The server contains a list of permissions (according to Access Control List), which is programmed to allow the chip holder access only to the areas where the holder is allowed to access, and in times when the holder is allowed to access them. Identification cards are used for building entrances in a similar way. Unlike mechanical locks, it is possible to block the access after reporting the chip or identity card loss. Very often we can see association of an access control system with attendance control system. Generally we speak about Identity Management Systems.

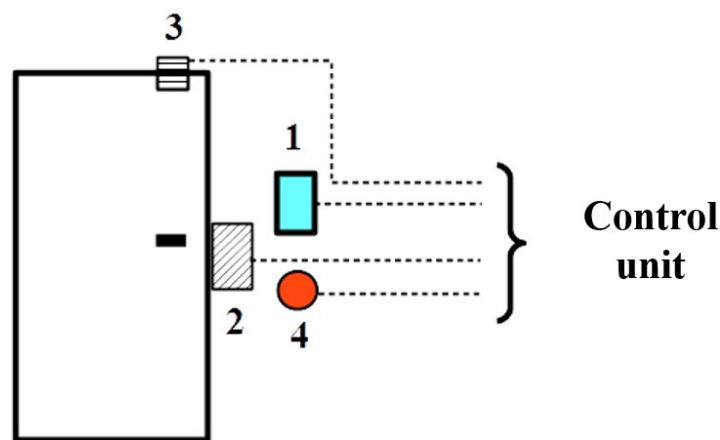

Fig. 2.1: Doors Security

Explanation:

1. Card or chip reader is placed on both sides of the door
2. Electric lock
3. Door contact
4. Emergency escape button is placed on both sides of the door

The normal state for the door is when it is closed and the door contact (3) sends a signal confirming that. A person who wants to enter is identified by chip or card. The reader transmits data to the control unit, where the identification code is compared to the list of permissions. In the case that a match is confirmed (relational operation of equivalence), an impulse is sent to open the electric lock. The impulse keeps the lock in the open position for a predefined time, e.g. 10s. A person opens the door and enters, which is indicated to the system by changing the state signal on the door contact. If the door opening time is shorter than the predefined one, changing of the state of the door contact ensures relocking of the door. If a person tries to enter without authorization, the door remains locked; in such case the attempt for unauthorized entry can be recorded in the system. The reading device usually provides feedback on allowing or denying the access, using either coloured LEDs or voice announcement.

During the operation of the building, states of emergency can occur. One of them is when the door contact is not sending a signal that the door is closed. The door may be secured by a wedge or have failed to close and lock. In both cases, the control unit sends an alarm message to the operator and the door must be checked on the spot. Another state of emergency occurs when it is necessary to open an emergency door during a fire alarm or when emergency medical care is needed for people inside the building. For this purpose, the emergency escape button should be used to unlock the door. The use of emergency escape button is also recorded on a central server.

Technologies providing access depend on the type of the reader. Readers can be divided into three categories:

- Basic readers,
- Semi-intelligent readers,
- Intelligent readers.

Basic (non-smart) card reader simply reads the card number and PIN, and transmits it to a control unit.

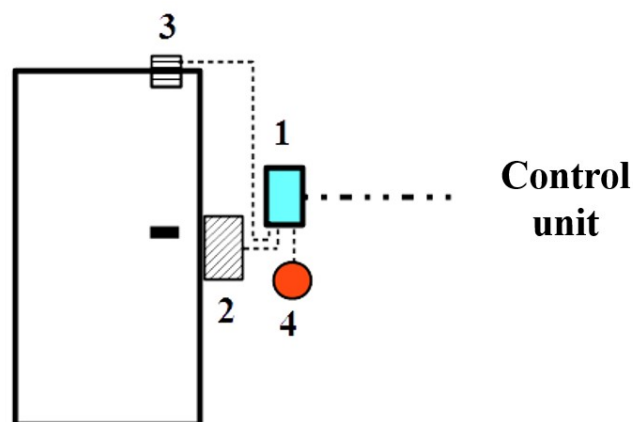

Fig. 2.2: Semi-intelligent card reader operation

Semi-intelligent card reader is linked directly with all the inputs and outputs necessary for monitoring of the door's hardware (electric lock, door contact, emergency escape button – see Fig. 2.2). Semi-intelligent reader does not make any decisions on the access.

Intelligent card reader is linked directly with all the inputs and outputs necessary for monitoring of the door, like the semi-intelligent one. Unlike semi-intelligent reader, it also has a memory and computing capabilities necessary to make decisions on the access independently of other devices.

Some readers are equipped with additional features, such as LCD displays and function keys for other inputs and outputs (camera, microphone, etc.).

2.2 Closed-Circuit Television

Closed-Circuit Television (CCTV) is currently used in a wide scale. Compared to television broadcast, CCTV is not distributed to the public. CCTV systems include video cameras, monitors and transmission networks, and the technology can be wired or wireless. CCTV is used for:

- Supervision and monitoring of guarded objects,
- Supervision and monitoring of public spaces, especially in the fight against crime and vandalism,
- Video conferencing or distance learning (also as video telephony),
- Process control in the industry,
- Surveillance of areas with potential health risk,
- Leisure-time activities (e.g. monitoring the behaviour of animals in the zoo, etc.).

Camera systems (WebCams) mostly work continuously. Modern CCTV uses advanced forms of digital storages for the recorded data.





Fig. 2.3: Cameras

The first closed-circuit television was commissioned by Siemens in 1942. The cameras for monitoring were placed in the testing facility of the German V-2 rocket site at Peenemünde, Germany. The design of this circuit was proposed by a German engineer Walter Bruch, who was also responsible for its installation. The US built their first CCTV called “Vericon” in 1949.

Early CCTV systems used fixed monitors, because it was not possible to record and store the information. Further development allowed recording on magnetic tapes, which had to be manually changed when the tape was full. The operation of such system was unreliable and expensive. In 1970, VCR (Video Cassette Recorder) technology enabled easier and more affordable recording and further manipulation. Another big step was possible after the introduction of digital multiplexing in 1990, which allowed recording of multiple camera inputs at once, saving time and money and resulting in extended use of CCTV. The current technology has been further developed to use Internet-based products and systems.

Currently, the technology of wireless IP cameras connected to a local area network (LAN) is used quite often. Internet protocol can transfer recordings from video servers over a public network to any computers or mobile device worldwide.

2.3 Fire Protection Systems

For reduction of consequences of fires, passive and active fire protection measures are used in buildings. Passive protection is focused on construction, materials and fire resistance of materials used in buildings. For active fire protection, the following technologies can be used:

- Fire Alarm Systems (FAS),
- Fire Suppression System (FSS),
- Smoke Exhaust Ductwork (SED).

Fire consequences are less severe if the fire is detected and reported as early as possible. The principle commonly used is quite simple: the building is divided into separate zones in order to limit the fire to the smallest possible space. These zones are equipped with systems for rapid identification of smoke or fire and its restriction in the area of detection. In the zone where fire is detected, fire suppression systems or smoke exhaust ductwork can be activated.

To avoid false alarms, several types of sensors (light, temperature, smoke, etc.) are installed in each fire zone. Evaluation of a fire breakout is based on signals from sensors in a binary logic circuit function called majority (usually majority 2 of 3). That means that if two of three sensors detect a fire then alarm will be triggered.

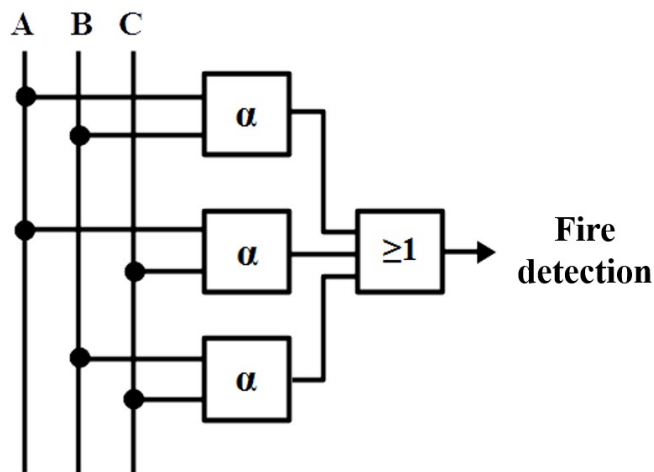

Fig. 2.4: Logical scheme

3 Transport Systems

Typical means of transport in buildings are:

- Escalators,
- Travellators,
- Elevators.

Escalator

$E=m \cdot c^2$

Escalator (also moving staircase) is a special conveyor designed for transporting persons between different height levels. It works on the principle of chain-connected steps circulating along a fixed track, allowing the step threads to remain horizontal. The chain conveyor is usually accompanied with a pair of handrails, which forms an escalator. The device is commonly driven by an asynchronous motor.

Escalators are used in subway stations, large shopping centres and other buildings with the need for transport of masses of people. The speed of the escalators is usually between 0.27 and 0.55 m/s; EU standard specifies the maximum speed as 0.75 m/s. Compared to elevator, escalator has a higher transport capacity.

Escalators are equipped with emergency stop buttons, which anyone can use. At least two emergency stop buttons should be installed on both ends of an escalator. Operational start of an escalator can be done manually by its operator or based on detection of the onset of a person.

Travellator

Travellator (moving walkway) is based on the same mechanical principle as escalator. It is used for horizontal transport or inclined transport of people.

$E=m \cdot c^2$

In comparison with escalator, travellator is used for smaller inclination transport and for horizontal transport. Surface of a travellator is simply a plane, and no elevated steps are formed.

Inclined plane design is commonly used in commercial centres. Horizontal design is often used to speed up passenger transport over longer distances (e.g. in airport corridors).

Elevator

$E=m \cdot c^2$

Elevator (lift) is a transportation mean for lifting persons or goods in vertical or diagonal direction along a fixed path. Elevator is basically a platform that is towed or pushed by a mechanical system, usually ropes, chains or hydraulic systems. Modern elevators consist of a cabin placed in the elevator shaft.

In the past, elevators were powered by water, steam or even human power; today, electric drives are used almost exclusively.

Elevator control is based on signals from control panels placed inside the cabin and at each stop of the elevator shaft. When passengers enter the cabin, the elevator is operated by pressing of a button or touch sensor. Older types of elevators respond to a request individually and accept another request only after the previous request has been finished. New types of elevators allow recording of multiple requests and on their way they can stop at several floors/levels.

Control panels also inform the passengers about the movement of the elevator both inside the cabin and at each stop. In order to start the operation, safety conditions have to be met.

In the case of failure, control panel allows the passengers to call for help. Control panels at each elevator stops are usually equipped with two buttons for direction of the desired movement, and they also show information about the current movement of the elevator. Based on the logic applied, the elevator, which is passing the stop, can take on more passengers who wish to travel in the same direction. In the case of managing a group of elevators, it is possible to call the nearest one.

If some of the elevator stops should have restricted accessibility, the control panel could require the use of mechanical key, chip card or password to allow the movement to the desired stop.

4 Building Energy Management

Important part of the costs in buildings is formed by energy consumption for lighting, heating, ventilation and air conditioning. In order to optimize the consumption, the introduction of energy management is necessary.

Energy consumption can reach up to 25% of the total operating costs of the building. The goal of energy management is to reduce energy losses and energy consumption. Technology roadmaps are often used by the owners of buildings to balance their investment and financial feedback just by use of Building Energy Management.

In this process, technology installed in a building is monitored and controlled. Therefore we have a control process, in which we try to achieve optimal operating costs for energy consumptions with minimal environmental impact. The energy management system is operated either with the help of special software, or customized SCADA and BMS systems – in general we talk about Building Automation systems. The software is operated by the management or by the maintenance operators with appropriate training, so that they are able to interpret the evaluated data correctly.

Main requirements on the organization

Energy management needs to be integrated in the organization structure in a way that provides maximum flexibility and efficiency, so that decisions made on energy management of the building can be implemented fast. In most cases the system is operated as a part of building or facility management. Facility manager then has to deal with economic and environmental objectives based on risk assessment and quality targets to reach optimal energy consumption. For small- and medium-sized buildings, energy management is usually only a partial job of facility manager, or it is even outsourced as a service.

Visualization and optimization

Visualization and optimization is nowadays a standard part of intelligent buildings operation. Functionality corresponds to the description in a chapter of SCADA systems. As a part of SCADA systems dedicated to energy management, we also get the visualization on energy efficiency, which is used to provide instant feedback on the status of energy consumption, and it also provides hints on identified optimization potential.

Practical measures in EM

To reach energy savings in buildings, the following measures are usually introduced: electricity consumption reduction by using energy-saving technologies, optimization of production and distribution of the heat, optimization of the HVAC operation, introduction of central monitoring and management, introduction of renewable energy sources, reduction of energy leaks in the building envelope, etc.

5 Optimization of Working Conditions

Most of the building technologies are related to working conditions – lighting, ventilation, heating or air conditioning, and therefore it is crucial to find the optimal way of control at minimal costs. The most common way for these technologies is to implement at least local control system with a regulation circuit.

5.1 Lighting

Lighting (today mostly used Energy Efficient Lighting) in the building management can be divided into three areas:

- Exterior building lighting,
- Lighting for common areas of the building,
- Room lighting.

From the point of the control, exterior lighting of a building is a typical example of logic control as it is turned on at specific time of day or when natural light intensity drops below the limit, or even manually. In order to reduce electricity consumption for lighting in common areas without natural lighting, it is possible to introduce regulation based on the signal from motion sensors and switch off control with predefined time delay. Room lighting is designed similarly as exterior lighting with logic control. To improve the efficiency of the system, zonal lighting is used for rooms with large area, or lighting intensity control is introduced.

5.2 Ventilation



Ventilation is a technological process consisting in controlled exchange of air in a given space.

Ventilation is performed by fans. The air flow rate (air volume per time unit) depends on the intended use of the ventilated space and is given by standards. From a management perspective, it is a logic control based on time and other factors.

5.3 Heating



Heating is a technological process, in which thermal energy is supplied to compensate energy losses of a building, and also to maintain the desired temperature in the building (when the desired interior temperature is higher than the ambient one).

Thermal losses of buildings are not affected only by the thermal difference between the indoor and outdoor areas, but also by insulation of the walls, location of the building, its shape and its structural arrangement. By definition, it is evident that in addition to the set temperature in the building, there are further control variables as the outdoor temperature and time.

Heat control is influenced by many factors:

- The location of the heat source – whether it is a centralized source of heat or local one;
- Type of heat transfer media – whether it is hot-water or steam system;
- Type of the heated object – whether it is a block of flats, offices, school or medical facility.

Thermal output control can be performed by:

- Control of the heat source;
- Central control of the heating system or of its parts;
- Local control of heat demands;
- Associated control, which is a combination of the options listed above.

Domestic hot water (DHW) supply is also very often a part of the heating system of a building. If the source of DHW is local, then its control should be a part of the building or heat control management system.

5.4 Air Conditioning



Air conditioning is a technological process that serves to maintain the desired temperature and relative humidity in a building. The values of temperature and relative humidity are set to a constant. The air conditioning unit, therefore, can heat, cool, humidify or dehumidify the air.

The air conditioner unit can be central for the whole building or local for each room individually. Central air conditioning units are equipped with heat recovery systems to save energy.

Besides special buildings, where it is necessary to condition the whole area, local conditioning of rooms is far more often, as it is described in the text below.

6 Sensors in Buildings

Whatever the decision-making process is, it is necessary to know the information about the state of the system and about the parameters that influence it. For people, this information is provided by human senses. In technical practice, to obtain an information about any parameter, we use sensors or transducers, which are able to measure certain physical or technical quantities and convert them into signals, which can be transmitted over long distances and further processed in measurement or control systems. Control systems perform evaluation of the information and they are able to transmit other signals to actuators. Information can be carried over by mechanical parts, gas or liquid, but in most applications, electrical signal is used, and therefore we will refer to electrical signals in the following text.



$E=m \cdot c^2$

A sensor is basically a measuring instrument that converts the measured quantity to binary or analog electrical signal, which can be evaluated.



1. Light barrier. It is an opto-electronic device consisting of a light source and a photodiode. Light barrier evaluates whether there is any obstacle in the space between the source and the photodiode.
 2. Strain gauge scale. The sensor is based on a strain gauge, which is basically a very thin electrical resistance wire attached to a component that allows its deformation. After deformation, the electrical resistance is changed. This resistance change is related to the strain by the quantity known as gauge factor.
-

An important parameter of each sensor is its sensitivity and measuring range. It is crucial for sensors that their design should not affect the measured value of the respective physical quantity. Due to this condition, sensors are becoming smaller and their sensitivity higher. Technological progress allows production of sensors in a microscopic scale, such as microsensors using MEMS (Microelectromechanical Systems) technology. In most cases, microsensors provide significantly higher signal feedback and sensitivity compared to macroscopic approaches. Recently, NEMS (NanoElectroMechanical Systems) technology has been also introduced to the markets.

In buildings there are used sensors that provide input information to a logic circuit or state controller. The following sensors are the most common ones:



Different types of readers for access control (chip or smart card, fingerprint reader, biometric readers, etc.).

Light barriers that interrupt the operation of machines if any object or person enters the working area of the machine.

Electromagnetic contacts for doors and windows, which determine their status. They raise an alarm when unauthorized opening is detected or when the doors are not closed in the prescribed time range. The sensors form a part of electronic security systems.

Fire alarms and smoke detectors, which are a part of fire protection systems.

Electromagnetic scanners, which are a part of the protection against shoplifters or prevent armed people from entering into restricted areas.

Motion sensors, which are most frequently used for automatic lighting or for security systems.

In buildings there are also sensors used for measurement of physical quantities and transducing them into electric signals, which are brought to the inputs of control logic. With respect to the measurement physical principle, the following types of sensors are most common:

Dependence of electrical resistance on temperature

$E = m \cdot c^2$

Any material changes its electrical resistance depending on the temperature. This principle is used for temperature measurement in resistance thermometers, also called resistance temperature detectors (RTDs). Because the resistance thermometer is in principle a passive element, power supply is necessary to operate it.

Resistance thermometer is basically a wire or a layered resistor. Materials with favourable characteristics are used, such as nickel (Ni) or platinum (Pt). Labelling of the sensors on the market consists of chemical symbols and numbers, e.g. Pt100 – it means a platinum sensor, which has electric resistance of 100 Ω at 0° C.

+

The change of electrical resistance is directly proportional to temperature. For platinum, change of the temperature by 3° C corresponds to 1 Ω of resistance change. For nickel, the change is twice higher, and therefore 3° C of temperature change correspond to 2 Ω of resistance change. Platinum thermometers are used in the range between -220 °C and 900 °C; the range for nickel thermometers is smaller, from -60 °C to 180 °C.

Thermoelectric effect

$E = m \cdot c^2$

Thermoelectric effect is a physical process that generates voltage as direct conversion of temperature differences in a junction of the two metals, and vice-versa. Connection of two different metals is called a thermocouple, and it is an active sensor (i.e. it generates electricity).

+

A thermocouple is constructed as a combination of two metals, either iron (Fe) & constantan (an alloy of copper and nickel in a ratio of typically 55% copper and 45% nickel) for temperatures from -220 °C to 750 °C, or platinum (Pt) & rhodium (Rh) for measuring temperatures from 0 °C to 1600 °C. Because of the large measurement range and ability to measure high temperatures, thermocouples are widely used in combustion chambers of power plants. Due to low generated voltage (several $\mu\text{V/K}$), it is necessary to add an amplifier to the measuring circuit.

To prevent creation of another thermocouple sensor in the circuit, it is necessary to connect the sensor with conductors made from the same material and to add a compensation resistor to the circuit.

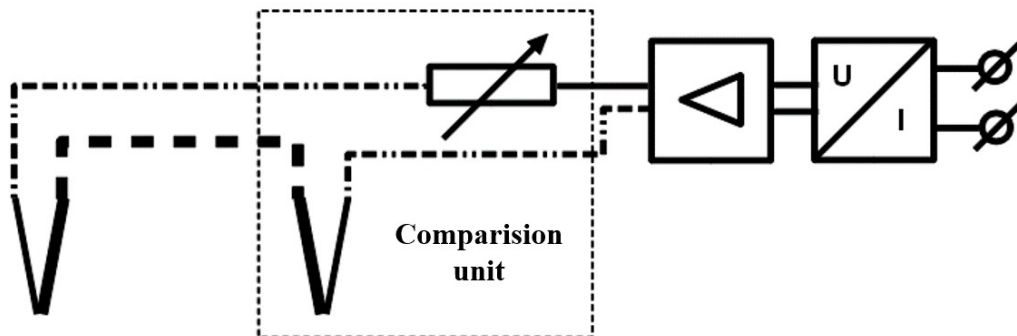

Fig. 6.1: Diagram of a thermocouple thermometer

To obtain stable measurement, standard configuration of a thermocouple contains reference junction, which is in fact another thermocouple placed in the environment with reference temperature, e.g. 20 °C. Then the measured value is the difference of temperature between the measured and the reference location. The measurement circuit contains an amplifier and a voltmeter – see Fig. 6.

Dependent electrical resistance of semiconductor elements

$E = m \cdot c^2$

This is again a measuring of electrical resistance dependent on the temperature, but in this case semiconductor materials are used. Measuring range is from -50 °C to 180 °C. These sensors are called thermistors. Thermistors are classified in two types – NTC (Negative Temperature Coefficient) and PTC (Positive Temperature Coefficient) thermistors. NTC thermistors have a negative trend characteristics, which means that the electrical resistance decreases with increasing temperature. PTC thermistors, in contrast, have a positive trend characteristics, which means that with increasing temperature the electrical resistance increases as well.

+

The advantage of these sensors is shorter response time and higher sensitivity (about 20 times) in comparison to RTD sensors.

-

- small measurement range,
- they don't have a linear characteristic,
- calibration curve is time-dependent.

The measured data can be substantially influenced by positioning of a sensor. The measured temperature depends also on type of object or media, in which the

measurement is performed. First of all, the measurement should not be influenced by external factors, which can be of many types – for example, unwanted cooling of the thermometer, influencing of the measurement by direct sunlight, improper placement in the stream of a medium, etc.

Principles of pressure measurement



$E = m \cdot c^2$

Instruments for measuring pressure are called manometers. Measurement of the pressure is not provided directly as it is necessary to convert the pressure to another physical quantity. Pressure can be converted to displacement of liquid in manometer tubes, or deformation of the measuring element causes the change of electrical or optical parameters that can be measured. The amount of pressure then corresponds to displacement or deformation of the measuring element.

Nowadays, the most common method of pressure measurement is to measure the deformation of a diaphragm, which is equipped with strain gauge.

7 Actuators in Buildings



Actuator is a device that acts in accord with a control signal and performs a change of its state, for example the drive, which ensures movement or controlling of mechanism or system according to the control signal.

Actuators can be classified according to their physical principles:

- Electronic – e.g. varicap;
 - Electromagnetic – saturable reactor;
 - Electromechanical – contactors; electric motors;
 - Hydraulic – hydraulic engines;
 - Pneumatic – pneumatic systems;
 - Unconventional – bimetallic; piezoelectric; electrochemical or other systems.
-



With respect to the type of output variable, we can classify actuators into two categories. The first type can operate in two discrete states; for example:

- Electric door lock, which allows to open a door based on the lock/unlock input;
- Contactor, which, for example, switches a heater on when the temperature in a boiler drops below the set limit;
- etc.

The second type of actuator has output variable, which changes between two limiting states; for example:

- Control valve supplying gas to a burner of a gas furnace. According to the difference between the actual and the desired temperature, the valve is opened more or less to change the gas inflow.
 - Reducing valve – performs reduction of a fluid pressure and maintains the pressure at the required level.
-

8 Control Systems

$E=m \cdot c^2$

Control system is a device (or set of devices), which manages, commands and controls behaviour of other devices or systems.



Control system may represent simple control of a machine that allows a worker to perform simple operations. An example could be a machine that is manually operated, but it is equipped with a safety logic ensuring that if a worker is in the workspace, the machine cannot be put into operation.

Automatic sequential control system may trigger a series of mechanical actuators in the correct order to perform the required task. An example of this may be increasing of the air flow when CO₂ limit is exceeded in a room. Use of PID controllers in such cases is very common and efficient. Control systems that include scanning and evaluation of the results to achieve the desired goal can adapt to constantly changing circumstances.

Nowadays, control systems use IP-based networks in buildings to communicate with each other and with supervisory systems, and to provide data and information to SCADA systems. The communication infrastructure is very often shared with other systems, such as VoIP (voice over IP), office network, etc. Due to this fact, the importance of network control safety is very high.

Two types of control systems are used in common – control systems with open or closed loop. In the open loop system, the output of the system is based on the input information.



Fig. 8.1: Direct control systems

In the closed loop system, the output is based partly or solely on the information obtained by feedback. This type of control system is therefore called feedback control system.

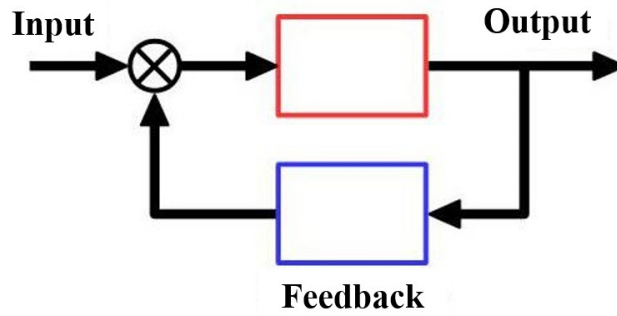

Fig. 8.2: Feedback control systems



Washing machine is an example of a control system with open loop. When the start button is pressed, a predefined and fixed program is executed. Human body is a typical example of a feedback control system.

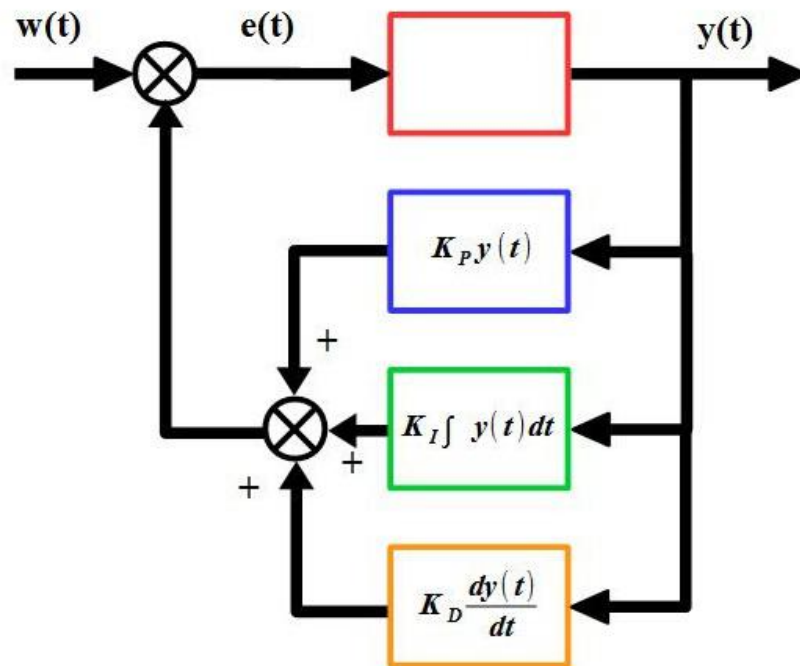

Fig. 8.3: PID regulator scheme

9 Buses and Protocols

Transmission of information between sensors, actuators and control centre is necessary for the building management. Information is converted into signals, which have to be transported.

9.1 Buses



Bus is a group of structured signal wires, which can be divided into the groups of control, address and data wires. Buses can be classified as serial and parallel ones. In the case of parallel buses, data words are carried over multiple wires simultaneously. In the case of serial buses, data words are carried in bit-serial form. Bus is intended to ensure the transmission of data and control commands between two or more electronic devices. Data transmission on the bus is ruled by an established protocol.

In the case of modular architecture of electronic devices or computers, bus is equipped with connectors adapted to connect the modules.

9.2 RS-232

Standard RS-232, respectively its last version RS-232C dating back to 1969 (also referred to as the serial port or serial line) is used as a communication interface for personal computers and other electronics. The individual data bits are transmitted sequentially (in series); one pair of wires is used in each direction. Unlike network technology (e.g. Ethernet) or USB interface, RS-232 is completely collision-free physical layer.



Fig. 9.1: 9-pin connector

Since 2010, RS232 has been replaced in most personal computers by a universal serial bus (USB). Modifications of RS-232 (standard RS-422 and RS-485) are used very often in the industry because of their specific features and it is certain that in near future they will not be replaced. In the reference model ISO/OSI, the RS-232 bus is represented only by the physical layer. The usual transfer rates are 115 200; 57600; 38400; 19200; 9600; 4800; 2400; 1200; 600; 300 bit/s. Actual (effective) speed is always lower, because to each of the 8 data bits transmitted, additional 1 start bit, 1 or 2 stop bits and also the parity bit are attached. Typical distance from device to device connected over RS-232 is 15 m depending on the capacity of cables; up to 300 m can be reached with low-capacity cables.

9.3 RS-422

RS-422 is a serial communication standard, which allows defining of electrical characteristics of digital circuits. By utilizing the potential difference between the wires (differential transmission), it is possible to achieve data rates up to 10 Mbit/s, and cable length can reach up to 1500 meters. The standard RS-422 defines only signal levels, while other characteristics are prescribed by other standards for serial interfaces. In most applications, RS-422 is used to extend the length of the RS-232 bus.

9.4 RS-485

EIA-485 (originally RS-485) is a serial communication standard defined in 1983 by EIA association. It is used mainly in industrial environments. RS-485 standard is designed to establish a two-wire half-duplex multi-point serial link. It has the same basis as RS-232, from which it differs in signal levels, the absence of modem signals and the possibility of networking of up to 32 devices. The serial link can reach up to 1200 meters. The advantage of RS-485 is also the possibility to create the RS-485 link from widespread standard RS-232 using simple level converters.

Sample of transmission of a character No. 211 (D3 in hexadecimal, 11010011 in binary code) is shown in Fig. 9.2. Firstly, the start bit is transmitted, then 8 bits starting with LSB, no parity, and the sequence is finished by the stop bit.

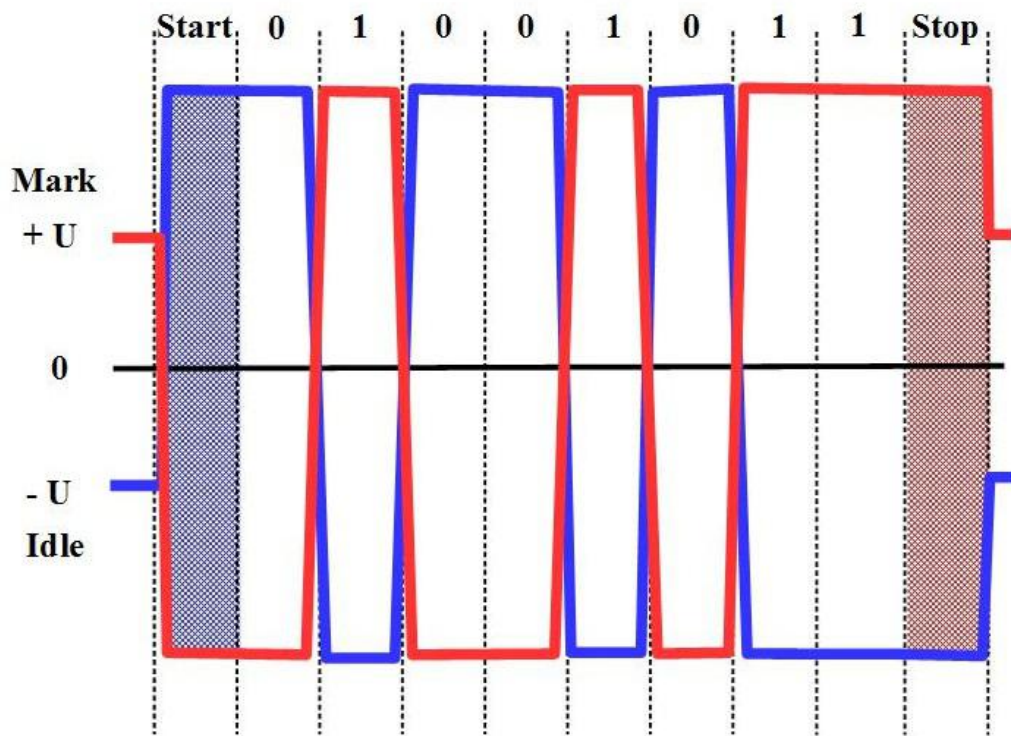

Fig. 9.2: Datagram RS-485 (transmission of character „K“)

RS-485 (same as RS-422) provides connection of the communicating units over a pair of conductors. These wires are labeled by letters A and B, sometimes also as "-" and "+". In the idle state, voltage should be lower on the wire labeled as A (or "-") in comparison to the wire labeled as B (or "+"). Even when working with the differential voltage, in the case of connections over longer distances it is necessary to connect also the ground (GND, G), not only the signal lines (+ RxTx and RxTx-) of the communicating devices (see e.g. Modbus specification). The reason is that in remote locations, there can be significant difference in the potential of the ground.

When communicating over long distances, terminal resistors should be applied on both sides of the line. The purpose of terminal resistors is to avoid reflections from the ends of the signal line, and also to increase the endurance of the line against interfering signals. Terminal resistors should ideally have the value of $110\ \Omega$ (i.e. image impedance), so that the resulting impedance of the line would be $55\ \Omega$ ($110\ \Omega \parallel 110\ \Omega$).

9.5 Modbus

Modbus is an open protocol for communication between various devices (PLC, touchscreens, I/O interfaces, etc.), which allows to transfer data across different networks and buses. Communication works by transmitting data words between a client and a server (master and slave).

Modbus protocol defines the structure of the message at the protocol level (PDU – Protocol Data Unit) regardless of the type of communication layer. Depending on the type of network where the protocol is used, the PDU can be extended to take part at the application level (ADU – Application Data Unit).

9.6 Other Protocols Used in Buildings

EIB (European Installation Bus) has a decentralized structure, which supports linear, loop, tree or star topology. It is primarily designed for electrical installations in buildings, and the connected devices can be supplied by electricity directly over the bus. KNX is a successor to the EIB standard with more features. M-Bus is used for connecting gauges, e.g. electricity meters, water meters and so on. LON is a widespread bus for buildings with LonTalk protocol. BACnet protocol is today very often implemented in its version BACnet/IP – a complex protocol defining objects, services and their links.

10 Supervisory Control Systems

This term is used for a computer-based control systems, which enable supervision, control and data management of technological process. The designation SCADA (Supervisory Control And Data Acquisition) is used for these systems.

$E=m \cdot c^2$

SCADA is a system operating with coded signals through communications channels to control a remote device. The control system is usually supplemented with a system for data acquisition on the state of the remote device, for data processing and data management.

Databases and programs of SCADA systems are connected to the HMI (Human-Machine Interface).

$E=m \cdot c^2$

HMI is a software that performs visualization of technological processes. HMI provides technology operator with detailed information on schemes of all sensors and devices, state of the technology, trends of the tracked parameters and diagnostic data.

SCADA contains:

- Remote terminals that convert signals of process sensors into digital data, which can be provided to the control centre;
- Scripting language that has the ability to perform control of partial technologies or functionalities in SCADA system;
- The possibility of connections to various networks – WAN (Wide Area Network), LAN (Local Area Network), Ethernet, etc.;
- Communication with computer HW via layers like HAL to provide faster displaying of graphs, data, etc., which could be crucial in the case of large data management.

The development of SCADA system was implemented in four generations:

- Individual systems. The system was realized by a microcomputer and it was autonomous. Common network services were not developed for SCADA at the time. Usually, SCADA was tailored individually for each customer.
- Distributed systems. Data processing was divided into several stations, which were connected over a LAN. Information was shared almost in real time. Each station was responsible for a specific task – thus, reduction of costs was achieved, compared to the first generation. Network protocols were used, but not standardized yet. Very few people other than developers knew about the installation of SCADA. Security measures for SCADA systems were usually overlooked.
- Network systems. SCADA system was divided into the simplest components connected through communication protocols. Several distributed SCADA

architectures were running in parallel with one of them being superior, which can be regarded as network architecture. This method enables cost-effective solutions even in very extensive systems.

- Internet systems. With the commercial availability of "cloud computing", SCADA systems increasingly adapt to use the Internet and IoT (Internet of Things) technologies. This allows significant reducing of infrastructure costs and costs for maintenance and integration.



The following SCADA systems can be found on the market:

- CITECT by Schneider Electric,
 - WinCC by Siemens,
 - RELIANCE by Geovap,
 - ControlWeb by Moravské Přístroje – www.mii.cz,
 - Wonderware In Touch by Schneider Electric,
 - RSView Studio by Rockwell Automation.
-